

# OneWrap

Pre-Stretch >>>> Productivity >>>> Robustness >>>>

## DATASHEET

SAFE • STRONG • SIMPLE

## Semi-Automatic Stretch-Wrapper

**OneWrap** is a semi-automatic machine to wrap palletized loads with stretch film. It provides versatile opportunities from essential level to moderate level usage. Starting from carriages with basic mechanical brake, up to the motorized Pre-Stretch version: **OneWrap** offers the right solution for most common pallet wrapping needs.

### KEY FEATURES

- ✓ **Safety First** – OneWrap incorporates several safety features as standard
- ✓ **No film waste** – with motorized Pre-Stretch system & independent tension control
- ✓ **Increased production capacity** – thanks to customized settings
- ✓ **Strong construction** – 2,4T load capacity for less effort in maintenance and flat operating cost
- ✓ **Flexibility** – machine easy to move with forklift (also after installation)
- ✓ **Easy-to-use** – due to the simple control concept
- ✓ **Modular system** – meeting your individual needs
- ✓ **Easy installation** – delivered with column already mounted
- ✓ **CE compliant** - engineered and produced in Italy according to EU safety standards

### DIMENSIONS

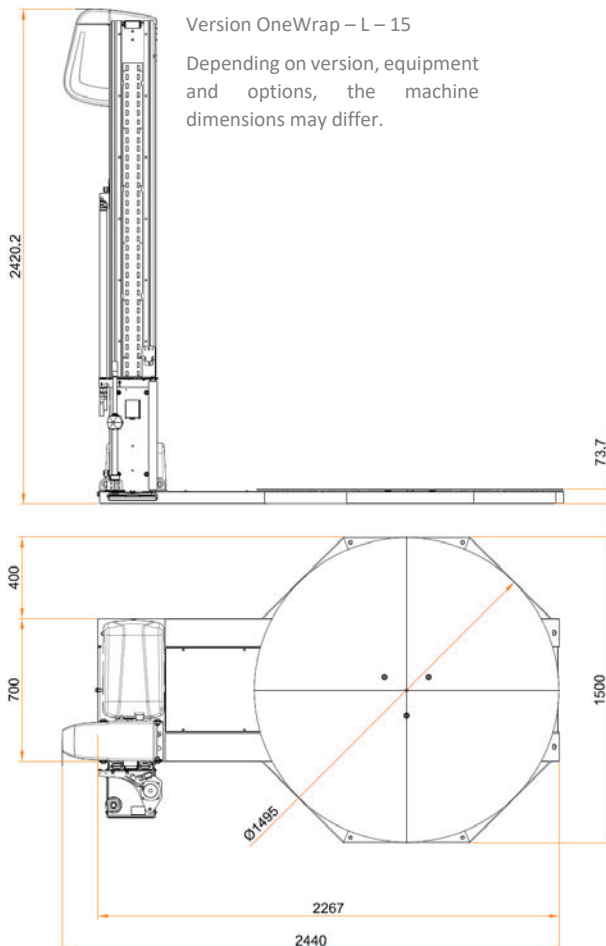

### CONTROL KEYBOARD



- User friendly icons and jog selector for quick parameter set-up
- 9 + 1 customizable programs
- Semi-automatic and manual working mode
- Individual Speeds for Up/Down carriage movement
- Separated set-up for top and bottom reinforcement wraps
- Emergency push-button according to regulations

## DATASHEET

Carriage type	LP	SM	FM	M	EM
Description	Powered Pre-Stretch	Mechanical Pre-Stretch	Electro-Magnetic Brake	Mechanical Brake incl. quick release	Mechanical Brake
Pre-Stretch level (%)	240 / 200 / 150	90 / 60 / 30	-	-	-
Platform diameter (mm)	1.500 std. / 1.650 / 1.800 / 2.200 / 1.500 HS (open turntable)				1.500
Max. pallet height (mm) incl. overlap above pallet top edge	2.100 std. (Low) / 2.400 (Medium)				2.100
Max. pallet size (mm)	800 x 1.200 - 1.550 x 1.550 (depending on turntable diam.)				800 x 1.200
Max. working load (kg)	2.400 std. (flat turntable) / 1.200 HS (open turntable)				2.400
Power supply	220/240V 50/60Hz / 400V 50/60Hz / others on request				
Platform rotation speed	6 – 12 rpm (adjustable) / 5 – 10 rpm (adjustable) for HS platform				
Max. noise level	72,0 dB(A)				
Operating temperature	5 – 40°C				
Film roll details (max.)	width 500 mm / ext. $\Phi$ 300 mm / core $\Phi$ 76mm (fix) / weight 20 kg / thickness up to 35 micron				
Features	LP	SM	FM	M	EM
Manual + 4 Automatic modes	•	•	•	•	•
9 + 1 individual programs	•	•	•	•	•
Pre-Stretch system	•	•	-	-	-
Adjustable film tension from control panel	•	-	•	-	-
Smooth Start / Stop	•	•	•	•	•
Independent setting of rotation & carriage speeds	•	•	•	•	•
Lockable Control Panel	•	•	•	•	•
Top-Sheet function	•	•	•	•	•
No. of Top- & Bottom windings (independent settable)	•	•	•	•	•
Automatic height detection	•	•	•	•	•
Top edge overlap (settable from control-panel)	•	•	•	•	•
Adjustable bottom overlap	•	•	•	•	•
Auto. film break detection	•	-	-	-	-
Pausable wrapping cycle	•	•	•	•	•

### OPTIONS & ACCESSORIES

- Photocell for dark or reflective surfaces
- Standard ramp; L=1.490mm
- Elongated ramp; L=1.870mm (for loading with pallet truck)
- Pit-frame for installation at ground level
- Film cutting punch (only on LP-carriage)
- Carriage for net-film
- Weighing system with control keyboard
- Low temperature version (-20° C)
- Stainless steel version



### FILM CARRIAGES



### MORE DETAILS

Videos and further information can be found on our website or SIAT Youtube channel.

